

DynaComm Connectivity Series®

for the Windows® CE Operating System

Getting Started

Thank you for purchasing DynaComm Connectivity Series® for the Windows® CE Operating System (DCS). DCS is the first product of its kind powerful enough to offer multiple host connectivity on handheld devices and Windows-based Terminals (WBTs). DCS combines the power of the enterprise with the flexibility of mobile computing. Adapted from DynaComm Connectivity Series 7.0—FutureSoft's PC- and Web-to-host connectivity solution—DCS provides remote access to most major host systems including IBM, Tandem, Digital, and UNIX.

DCS brings portable computing into the mainstream of enterprise computing by allowing access to host-based applications. No longer just a device for email or maintaining a calendar, DCS allows devices powered by Microsoft Windows CE to become true computing

appliances that extend the reach and accessibility of enterprise applications. Businesses now have a new way to deploy mission-critical applications as they seek new competitive advantages. This offering will provide seamless connectivity to anyone traveling or working from remote locations.

DCS contains a wide variety of terminal emulations enabling DCS to emulate a terminal on most large remote systems. DCS contains the following emulations: ADDS VP/60; ANSI-BBS; AT&T 605/705; TeleVideo 925; Digital VT-52, 100/102, 220, 320, and 420; and Wyse 50/60. FutureSoft offers other emulations that you can purchase separately as a DynaComm Client Option® for the following terminals: AT&T 4425, IBM 3270, IBM 5250, and Tandem 6530.

Package Contents

The package for DCS contains the following items:

This Getting Started card.

Floppy disks (3.5 in.) containing DCS, or any DynaComm Client Options you may have purchased.

Documentation

This Getting Started card as a printed document provided with the installation floppy disks.

This Getting Started card as a PDF (Portable Document Format) file called GtStrt.PDF. The file is located in the DCS installation directory on your desktop computer.

An online help file (DynaCE.HLP) located in the DCS installation directory on your desktop computer.

System Requirements

Windows CE Services 2.0, or higher, installed on your desktop PC.

A device powered by Microsoft Windows CE 2.0, or higher, utilizing a MIPS or SH3 processor. FutureSoft will support additional processors as the market demands. If your device has a processor other than a MIPS or SH3 processor, contact FutureSoft for more information.

Installing or Removing DCS

Overview

Installing DCS or a DynaComm Client Option is a two-step process. First, you must copy the installation image of the DCS files onto your desktop computer, using the DCS Installer. Besides copying installation files to your desktop computer, the Installer also registers DCS with the Application Manager (CEAppMgr.EXE), which is a part of the Windows CE Services on your desktop computer. Second, the Application Manager must install DCS from the desktop computer to the device powered by Microsoft Windows CE.

Note: You must install the core DCS product before installing any of the DynaComm Client Options.

When removing DCS, you have three basic options. The removal option you choose depends on the storage needs of your desktop

computer and the device and how you use DCS. The first removal option uses the Application Manager to remove DCS from the device, while keeping DCS registered in the Application Manager. This choice allows you to remove DCS from the device when you temporarily need the storage space for another program. When you want to reinstall DCS on the device, the Application Manager allows you to do so without setting up the files on your desktop computer again.

The second removal option uses the Application Manager to remove DCS from the device and to delete the DCS registration from the Application Manager. This choice allows you to reclaim space on the device and requires you to completely reinstall DCS on the desktop computer and the device before you can run DCS again. This choice is useful when you upgrade DCS.

The final removal option removes the installation image of DCS from the desktop computer. This choice allows you to free disk storage space on your desktop computer, while keeping DCS registered with the Application Manager.

Installing

Installing DCS requires you to have installed Windows CE Services (version 2.0, or higher) on your desktop computer. The DCS Installer does not require that your device be turned on and connected to the desktop computer; however, if the device is on and connected, the Installer will automatically start the Application Manager after the Installer has copied and registered the installation image on your desktop computer. The Application Manager will then install DCS on your device, installing DCS in one step.

Note: Only install DCS or any of the DynaComm Client Options in the *default application install directory*.

Installing the Installation Image on the Desktop Computer

- 1 Insert Installation Disk 1 into the floppy drive of the desktop PC.
- 2 Open Installation Disk 1 on the desktop computer.
- 3 Double-click Setup.EXE to start the installation. The Installer will guide you through each step of the process, asking you to accept the license for DCS (or one of the DynaComm Client Options), provide information for your copy of DCS, specify a location for the installation image of DCS, name the DCS program shortcut (which will appear in the Windows Start menu on the desktop computer), and view the Readme.

During the installation, the Installer gives you a choice between a *Typical* or a *Compact* installation. The Typical installation contains all of the components of DCS, and the Compact installation contains only the basic DCS components and is for devices with constraints on the available memory. The Compact installation contains the following components: the Telnet connector, the ANSI-BBS and Digital VT emulations, and the

Kermit and ZModem file transfer protocols. The Compact installation does not contain the Modem and Direct Serial connectors and the following terminal emulations: ADDS VP/60, AT&T 605/705, TeleVideo 925, and Wyse 50/60.

- 4 Click Finish in the last dialog of the installation. If the device is connected to the desktop computer, the Application Manager will automatically start installing DCS on the device. However, if the device is not connected to the desktop computer, the Application Manager will start and indicate that it will install DCS the next time the device and the desktop computer are connected.

Installing DCS on the Device after Installing and Registering the Installation Image

After you click Finish in the last dialog of the DCS installation, or after you have connected the device and desktop computer, the Application Manager will start automatically on your desktop computer, asking you whether DCS should be installed in the default application directory.

Click Yes to install DCS, or click Cancel to stop the installation process. If you click Yes, the Application Manager will display a dialog with a progress bar. When the Application Manager on the desktop computer indicates that the download is complete, the device will then show the installation progress. While the installation is completing on the device, click OK in the Application Downloading Complete dialog on the desktop computer to close all of the Application Manager dialogs.

If you click Cancel, you may install DCS or a DynaComm Client Option at a later time on the device. To install, see the section, "Installing DCS on the Device After Removing DCS from the Device," below.

Installing DCS on the Device after Removing DCS from the Device

This procedure assumes that you have already installed an installation image onto the desktop computer, and that you have not deleted or uninstalled the installation image, and have not deleted the DCS registration from the Application Manager.

- 1 Connect the device and desktop computer physically (for instance, through a serial port, an Ethernet network, an infrared connection, modem, or some other connection).
- 2 Start Windows on each computer.
- 3 After Windows has booted on each device, open the Mobile Devices folder in My Computer.
- 4 Make sure that the device and the computer have established a *partnership connection* over the physical connection.
- 5 Select Application Manager in the Tools menu in the window for the Mobile Devices folder.

- 6 In the list box of the Application Manager dialog, check FutureSoft DCSCE (and the names of any DynaComm Client Options).
- 7 Click OK in the Application Manager dialog. The Application Manager will then start downloading DCS to the device, as described in the section "Installing DCS on the Device after Installing and Registering the Installation Image," above.

Removing

Removing DCS from the Device

Using the Application Manager

Perform the same steps as in "Installing DCS on the Device after Removing DCS from the Device"; however, in step six, uncheck the items that you want to remove from the device.

Using the Remove Programs Control Panel on the Device

- 1 Select Start in the Windows Taskbar on the device. Windows will display the Start menu.
- 2 In the Start menu, select Settings and then Control Panel.
- 3 Double-click Remove Programs in the Control Panel folder. Windows will display the Remove Program Properties dialog.
- 4 Select FutureSoft DCS (or an installed DynaComm Client Option) in the Remove Program Properties dialog.
- 5 Click Remove in the Remove Program Properties dialog. The control panel displays a confirmation dialog.
- 6 Click Yes in the Remove Program confirmation dialog.
- 7 To remove other installed components, repeat steps four through six.
- 8 Click OK in the Remove Program Properties dialog.

Removing DCS From the Application Manager

This procedure deletes a registered component (DCS or a DynaComm Client Option) selected in the Application Manager and deletes the component from the device.

- 1 Connect the device and desktop computer physically (for instance, through a serial port, an Ethernet network, an infrared connection, modem, or some other connection).
- 2 Start Windows on each computer.
- 3 After Windows is running on each device, open My Computer on the desktop computer, and then open the Mobile Devices folder.

- 4 Make sure that the device and the computer have established a *partnership connection* over the physical connection.
- 5 Select Application Manager in the Tools menu in the window for the Mobile Devices folder.
- 6 In the list box of the Application Manager dialog, highlight FutureSoft DCSCE (or the name of a DynaComm Client Option).
- 7 Click Remove in the Application Manager dialog. The Application Manager will display a confirmation dialog.
- 8 Click OK in the Remove Application confirmation dialog.
- 9 To remove other components, repeat steps six through eight.
- 10 Click OK in the Application Manager dialog.

Removing the DCS Installation Image from the Desktop Computer

Note: This Uninstaller removes both the DCS installation image and any of the installation images for DynaComm Client Options.

- 1 Select Start on the Windows Taskbar on the desktop computer. Windows will display the Start menu.
- 2 In the Start menu, select Settings and then Control Panel.
- 3 Double-click Add/Remove Programs in the Control Panel folder to display the Add/Remove Program Properties dialog.
- 4 Select the Install/Uninstall tab.
- 5 Select DCS in the list box.
- 6 Click Add/Remove to start the DCS uninstaller.

How To Use DCS

On your device, DCS allows you to interact with a remote host or a BBS. You can quickly configure an emulation, a file transfer protocol, and a connector, and then connect to a remote system. And, if you want to connect to the same system again, you can save the configuration to a file. To connect to the remote system again, double-click the file, and DCS connects to the system.

To Start DCS

- 1 Select the Start button in the Windows taskbar to display the Start menu.

- 2 In the Start menu, select Programs and then DCS. DCS will start and open a default session window.

Note: To start DCS from the Windows desktop, make a shortcut for DynaCE.EXE or a session file on the desktop.

To Stop DCS

Select the Close button (**X**) in the upper right corner, or select Close in the File menu. If you have not saved the session configuration to a file when you exit DCS, it will ask you to save the configuration. After you have saved the session configuration to a file or deleted the session configuration, DCS will then close.

To Configure a Session

A session file specifies the configuration of the session window. Most importantly, a configuration specifies the method of connecting to the remote system (the connector), how to transfer files (the file transfer protocol), and the terminal that DCS will emulate while connected to the remote system (the emulation). Besides the connector, file transfer protocol, and emulation, you can also configure how the session will look as well as other options. The steps below are an overview of configuring a new session. For more details, see DynaCE.HLP on your desktop computer.

- 1 Start DCS as described above in "To Start DCS." An empty session window will open with the default configuration.
- 2 Select Properties in the Session menu. DCS displays the Session Properties dialog with the Connectors tab highlighted.
- 3 Select the name of a connector: Telnet, Modem, or Direct Serial.

Note: If you selected the Compact Installation, Telnet is the only available connector.

- 4 Click Properties to configure the properties of the connector that you selected. Minimally, the Telnet connector needs the address or name of the host, and the Modem connector needs the telephone number of the system. Depending on the connection and type of session, you may need to make further changes to the properties of the connector. For changes to the Telnet connector, select the Terminal or Other tabs. For changes to the Modem connector, click the Modem Properties button and the Dialing Properties button in the TAPI Properties dialog.
- 5 After configuring the connector, click the Close button (**X**) in the connector's dialog.
- 6 Select Emulations in the Session Properties dialog.
- 7 Select the name of an emulation in the list box.

- 8 Click the Properties button to display the emulations dialog and to configure the emulation. Besides configuring the emulation's parameters, the Keyboard tab in the dialog also allows you to change the function of the keyboard and to create toolbar buttons.
- 9 After configuring the emulation, click the Close button (**X**) in the emulation's dialog.
- 10 Select File Transfers in the Session Properties dialog.
- 11 Select the name of a file transfer protocol. You should select a protocol that also exists on the remote system.
- 12 Click the Properties button if you must configure the protocol. For most connections, configuring the file transfer protocol is unnecessary.
- 13 After configuring the file transfer protocol, click the Close button (**X**) in the protocol's dialog.
- 14 Select Display in the Session Properties dialog.
- 15 Click the Properties button to display the Text Display Properties dialog. This dialog allows you to change the appearance of the session window and to determine the size of the session window's history buffer.
- 16 After configuring the session display, click the Close button (**X**) in the Text Display Properties dialog.
- 17 Select Options in the Session menu to display the General Options dialog. The configuration in this dialog determines whether DCS will automatically attempt to connect a session when you open a session file and determines the function of your stylus.
- 18 After configuring the general options, click the Close button (**X**) in the General Options dialog.

The session is now ready to connect to the remote system. See "To Connect to or Disconnect from A Host" below.

If you want to save the configuration of this session, select Save or Save As in the File menu.

Tip: To start DCS with a saved session configuration, make a shortcut for the session on the Windows desktop.

To Connect to or Disconnect from a Host

To connect a session to a host, select Connect in the Session menu. DCS will then attempt to connect to the remote system selected in the Session Properties dialog. After DCS connects the session, Connect will become Disconnect in the Session menu. You can now log into and interact with the remote system.

To disconnect from a host, log out of the remote system and then select Disconnect in the Session menu.

To Use a Terminal Function

Each terminal emulation maps the functions of the terminal's keyboard to a key on the PC keyboard. Some of the terminal keys and functions are naturally the same on the PC keyboard, such as the alphanumeric keys, Shift key, and Enter key. However, some terminal functions must be accessed via key combinations or the PC's function keys.

The nature of the keyboard of most devices powered by Windows CE precludes the use of function keys and some key combinations, that a terminal emulation on a desktop computer might allow. For terminal functions without a natural equivalent on the device, select the Keys menu, hold down any modifier keys (the Alt, Ctrl, and Shift keys) that may be required, and then select the name of the terminal key or function in the menu. The content of the Keys menu depends on the terminal emulation that you selected in the Emulations dialog (Session > Emulation).

Besides the Keys menu, the properties dialog of each emulation has a Keyboard tab, which allows you to use the DCS Keyboard Map Editor to redefine the function of the keyboard and to create toolbar buttons for the session. The Keyboard Map Editor can configure keys or toolbar buttons to perform a terminal function or to send a sequence of characters or an escape sequence. For more information, see the "Keyboard for a Session" topic in the online help (DynaCE.HLP) on the desktop computer.

To Save the Current Session Configuration

After configuring or changing a session window with options in the Session menu (as in "To Configure a Session"), select Save or Save As to save the configuration to a session file.

Visual Quick Reference

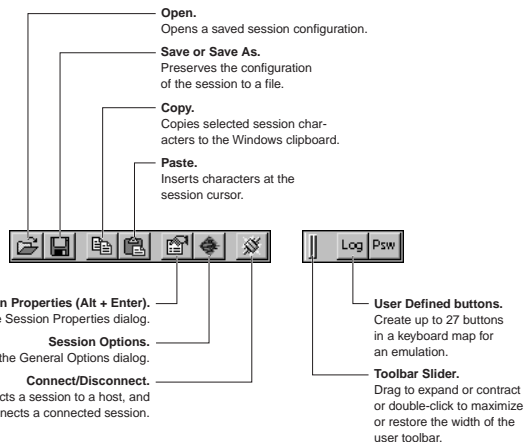
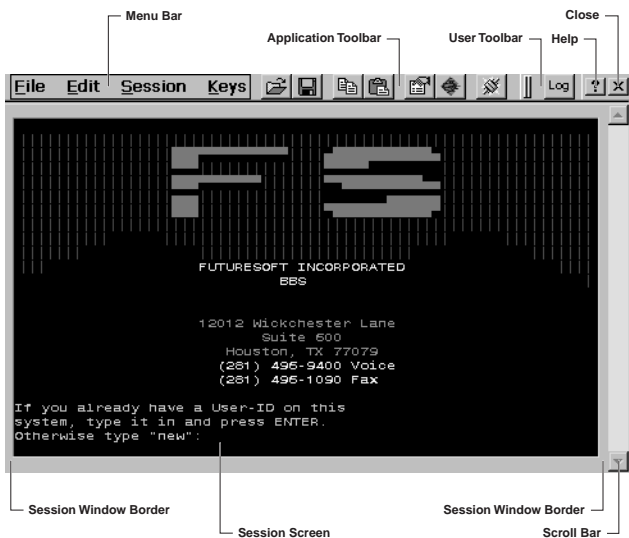

File	
Open...	Open Closes the current session, allows you to select a previously saved session configuration, and opens the file.
Save	Save Preserves the configuration of the session window to a file with a SES file type. You must name previously unsaved configurations.
Save As...	Save As Saves a previously saved session configuration under another name.
Close	Close Closes an ongoing session and then DCS.
About	About Displays version information about DCS.

Edit	
Copy	Copy Copies characters currently selected in the session window to the Windows clipboard.
Paste	Paste Inserts characters, previously copied to the Windows clipboard, at the current location of the session cursor.
Select All	Select All Highlights the entire contents of the active session (not its history buffer).
Send	Send Transfers a selection in a connected session to its remote system and is equivalent to selecting Copy and then Paste in the session.
Clear Screen	Clear Screen Deletes all characters in the active session screen.
Copy Screen to Buffer	Copy Screen To Buffer Copies the active session screen to the session window's history buffer (defined in the Text Display Properties dialog).

Session	
Connect	Connect/Disconnect Connects an unconnected session to a host, and disconnects a connected session.
Properties...	Properties Displays the Session Properties dialog, where you configure a connector; a terminal emulation, including keyboard configuration and toolbar creation; a file transfer protocol; and text display properties in the session.
Options	Options Displays the General Options dialog, where you configure whether DCS will automatically attempt a connection and how the stylus functions in the session.
Send File...	Send File Displays the Send dialog, where you select a file to send to a host after the system is prepared to receive the file.
Receive File...	Receive File Displays the Receive dialog, where you select a path name for a file, that a host will send to DCS.
Reset	Reset Displays a sub-menu of options for changing the operation of the emulation (see below).
Break	Break Sends a break signal to the remote system, pausing the host from sending data.

Reset	
Hard Reset	Hard Reset Resets the terminal emulation to the default settings of the terminal, and clears the buffer of the session.
Soft Reset	Soft Reset Aborts the current activity of the emulation.
Reset to Defaults	Reset To Defaults Resets the emulation to the configuration that you created for the session.

Keys	
PF1	Keys Menu The contents of the Keys menu are options corresponding to terminal and keyboard functions of the emulation chosen in the Session Properties dialog. The contents of the menu changes, depending on the selected terminal emulation.
PF2	

How to Contact FutureSoft

For further information, please contact FutureSoft at:

FutureSoft, Inc. 12012 Wickchester Lane Suite 600 Houston, Texas 77079-1222
Voice: 281.496.9400 **Fax:** 281.496.1090 **Email:** info@futuresoft.com **Web:** www.futuresoft.com

FutureSoft Europe b.v. Nijverheidsstraat 12 2288 BB Rijswijk (The Hague) The Netherlands
Voice: +31 (70) 390 7727 **Fax:** +31 (70) 390 7005 **Email:** info@futuresoft.com **Web:** www.futuresoft.com

For technical support, please contact FutureSoft at:

Email: support@futuresoft.com **Voice:** 281.588.6868